

INTERCONNECTION OF INDUSTRIAL ARCHITECTURES

IPL & SIG industrial routers are used to simply and safely interconnect remote industrial equipments.

These highly resistant products are dedicated to water, energy, industry and smart cities markets.

Router Firewall IPL & SIG

- **VPN concentrator**
(10 up to 1000 tunnels)
- **MultiWAN**
(Ethernet, ADSL, 4G/3G+, Wi-Fi)
- **High availability router with backup**
- **Wi-Fi**
(Access Point & Client)
- **Alert & Display**
(SMS, E-mail, Datalogger)
- **Tracking (GPS)**
- **5 years warranty**



CONNECTING TO A SCADA SYSTEM

Building of a complete solution with a SIG located close to the SCADA system. The IPL located onto the remote sites are interconnected to the SIG (VPN tunnels)

If the number of remote sites is large, two SIG can be installed in parallel to share the throughput.

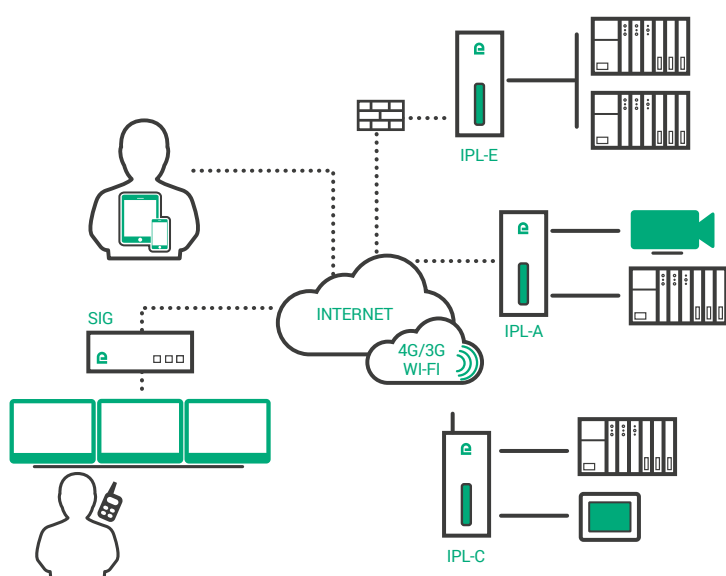

You can access from your tablet or smartphone to remote devices via the SIG (VPN, HTTPS)

INTERCONNECTING REMOTE EQUIPMENT

Using VPN technology (OpenVPN, IPSEC), you can safely interconnect equipment. One of the IPL will act as a VPN concentrator.

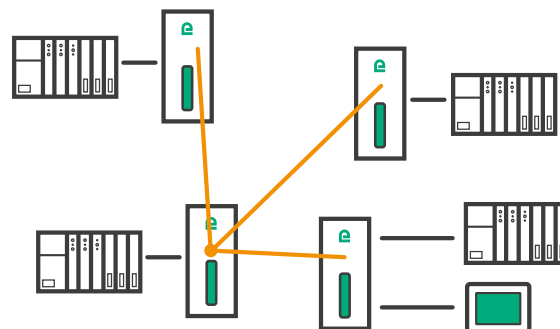

Remote sites can be interconnected via cellular IPL using Etic Telecom proprietary DYNDNS function. You would thus only need a basic data subscription with a non fixed public IP address.

ROUTERS WITH EMERGENCY BACKUP LINK

Critical sites can also be equipped with IPL routers capable of managing a main link and a backup link.

For example, the IPL-DAC router allows you to switch data over the 4G / 3G+ network when the ADSL link fails.

IPL-WAN-CODE 1-CODE 2

WAN can be Cellular (C and CW with Wi-Fi), ADSL (A and AW with Wi-Fi), Ethernet (E and EW with Wi-Fi), ADSL with backup cellular (DAC), Ethernet with backup cellular (DEC), ADSL with backup Ethernet (DAE), serial (S), PSTN (M).

CODE 1	100*	400	220	230	260	261
Ethernet 10/100 MDI MDIW	1	4	2	2	2	2
RS232 link	-	-	1	2	-	-
Non isolated RS485 link			1			
Isolated RS485 link						1
Isolated 422 link					1	
USB link		1	1	1	1	1
CODE 2 (CELLULAR WAN)	HG	LE	LS	LA	CH	
	3G+ "Word Wide"	4G Europe	4G USA 3G+	4G Asia 3G+	4G China	

*not available for ADSL, -D, -S, -M IPLs

SELECTION GUIDE



IP ROUTER	IPL-C OR IPL-CW	IPL-A OR IPL-AW	IPL-E OR IPL-EW	IPL-DAC	IPL-DAE	IPL-DEC	IPL-S	IPL-M	SIG E-400	SIG A-400	SIG EC-400	SIG VM
WAN 1	4G/3G+	ADSL	Ethernet interface	ADSL	ADSL	Ethernet	RS232 PPP	PSTN V34	Ethernet interface	ADSL	4G/3G/GPRS	Depending on HW platform
WAN 2				4G/3G/GPRS	Ethernet	4G/3G/GPRS					✓	
VRRP protocol	✓	✓	✓	✓	✓	✓			✓	✓	✓	✓
Backup link				✓	✓	✓					✓	
Number of VPN tunnels	10	10	10	10	10	10	1	1	100	100	100	1000
QoS	✓	✓	✓	✓	✓	✓			✓	✓	✓	✓

ACCESSOIRES



	ANT305	ANT310	ANT320	ANT217	ANT311	ANT219	ANT405
Type	Panel Mount	Roof	Magnet	Panel Mount	Roof	Magnet	Magnet
Network	2G - 3G - 4G	2G - 3G - 4G	2G - 3G - 4G	Wi-Fi (2.4 and 5 GHz)	Wi-Fi (2.4 and 5 GHz)	Wi-Fi (2.4 GHz)	GPS (1.57 GHz)
Connector	Male SMA	Male SMA	Male SMA	Male RP SMA	Male RP SMA	Male RP SMA	USB
Cable	-	5m	3m	-	3m/5m	1m	3m
Dimensions	H = 82mm Ø = 48mm	H = 82mm Ø = 48mm	H = 82mm Ø = 48mm	H = 90mm	H = 82mm Ø = 48mm	H = 220 mm	H = 15mm Ø = 38mm

5m coaxial extension : CO-LL6-SF-SM-500

TECHNICAL CHARACTERISTICS

GENERAL CHARACTERISTICS		LAN NETWORK	
Dimensions	<ul style="list-style-type: none"> IPL-X-100 : 120 x 37 x 88mm (h,l,d) IPL-E : 135 x 47 x 115mm (h,l,d) IPL-M : 130 x 38 x 110mm (h,l,d) SIG : 45 x 240 x 240mm (h,l,d) 	Ethernet	RJ45, 1 up to 4 ports depending on model
Weight	<ul style="list-style-type: none"> IPL : between 500g and 650g depending on model (without packaging) SIG : 1 300g 	RS232/RS485	<ul style="list-style-type: none"> 9600 up to 115200bps 10 or 11 bits RAW TCP server, TCP client & UDP gateway ModBus master or slave gateway Unitelway gateway for master PLC RS232 : RJ45 RS485 : 2 points phoenix connector
Power	<ul style="list-style-type: none"> IPL-X-100 : 10 - 30 VDC IPL-E : 10 - 60 VDC IPL-M : 10 - 160 VDC SIG : 110 - 230 VAC Phoenix connector 2 points 	Wi-Fi	Access point 2.4 and 5 GHz depending on model
Consumption	<ul style="list-style-type: none"> IPL-E, IPL-M : 2W IPL-A, IPL-EC and IPL-EW : 5W, IPL-ECW : 8W SIG : 10W 	ROUTING / IP@ / MANAGEMENT	
Temperature	<ul style="list-style-type: none"> IPL : -20°C - +70°C (* LTE : 60 °C - -40 °C with tropicalisation) SIG : -20°C - +60°C Humidity 5 to 95 % 	Routing IP	<ul style="list-style-type: none"> Static routes RIP or OSPF Address translation (DNAT and NAT 1:1)
CEM	<ul style="list-style-type: none"> Immunity (EN 61000-6-2) EN61000-4-2 : Electrostatic discharge (ESD) EN61000-4-3 : RF radiated EN61000-4-4 : EFT/Burst EN61000-4-5 : Surge EN61000-4-6 : RF Conducted Emission (EN 61000-6-4) EN 55022 : Radiated and Conducted emission 	Assigning IP@	<ul style="list-style-type: none"> WAN interface: DHCP client or fixed IP LAN interface: DHCP server
Electrical Safety	EN 60950	DNS	<ul style="list-style-type: none"> WAN interface: compatible with DYNDNS, No-IP or ETIC DNS LAN interface: relay & DNS server
Hazardous substances	<ul style="list-style-type: none"> Directive 2002/95/CE (RoHS) REACH 	Management	MIB 2 and Traps SNMP
Casing	<ul style="list-style-type: none"> IPL: IP20 metallic with DIN Rail mounting SIG: IP20 metallic 	Configuration	Web Server
WAN NETWORK		SECURITY	
Ethernet/ADSL	RJ45	Firewall	<ul style="list-style-type: none"> Stafeful packet inspection (SPI : 50 rules) Filtering IP@ and Ports
4G/3G+	<ul style="list-style-type: none"> 4G LTE Europe, USA, Asia, China 3G+ HSUPA "world wide" 850/900/1700AWS/1800/1900 MHz Max. data rate 4G: UL @ 50 Mbps and DL @ 100Mbps Max. data rate 3G+ : UL @ 5,7 Mbps and DL @ 21 Mbps Max. data rate 2G : UL @ 237 Kbps and DL @ 237 Kbps Antenna SMA female connector Certified antennas: see selection guide 	Internal report	<ul style="list-style-type: none"> Timestamped Events: connection, restart, alarms
Wi-Fi	<ul style="list-style-type: none"> Client 2.4 and 5 GHz depending on model 802.11 a/b/g/n and super AG Antenna connector Female RP SMA Certified antennas: see selection guide 	Alarms	<ul style="list-style-type: none"> Digital input: email, SMS, SNMP trap Digital output: Power supply failure, user connection...
PSTN network	<ul style="list-style-type: none"> RJ45 connector PSTN V90 modem Autoadaptable all countries 	Redondancy	VRRP protocol RFC 3768
		VPN	
		VPN tunnel	<ul style="list-style-type: none"> OpenVPN (TLS/SSL), IPSEC, L2TP / IPSEC, PPTP Shared Key or X.509 Certificate Encryption 3DES & AES 128-192-256 Authentication: MD5 & SHA-1 Up to 10 VPN tunnels (mix OpenVPN and IPSEC allowed)
		Number of VPN tunnels	<ul style="list-style-type: none"> Up to 10 VPN tunnels (IPL) Up to 100 VPN tunnels (SIG) Up to 1000 VPN tunnels (SIG VM) (Please contact us to port the SIG VM on a platform)
		Remote access	<ul style="list-style-type: none"> Up to 25 users with login and password Individual access rights to the device https portal enabling easy access to the remote html servers

Since 1985, Etic Telecom designs and markets industrial telecom solutions to interconnect machines with each other.

Etic Telecom is dedicated to the supply of safe, simple and sustainable products (3S).

etic
TELECOM

13, chemin du Vieux Chêne
38240 Meylan

Tel. +33 (0)4 76 04 20 00
Fax. +33 (0)4 76 04 20 01

www.etictelecom.com